

A. Package content

- Controller X 1, Warranty card X 1, Installation Guide X 1
- Accessory kit X 1(Screw X 4, Spacer X 4, 1N4004 X 1), Wiring sticker x 1

B. Installation

- Physical Dimension: 138 x 114 x 27 (mm)
- Recommended: Cable with shielded, Linear DC power supply, Network cable.

■ Specifications

- Voltage range: 9~24 VDC
- Controller Power Consumption: 180mA
(Exclude external device power consumption)
- Power recommend: 1A
(Includes relay expansion module and an external reader device power consumption)
- Please do not exceed 300mA for external wiegand reader
- Max distance for wiegand is 80M

■ Notice

- Do not connect other cables to the power unit except power contacts.
- Do not apply any unverified power supply to the unit.
(Might cause hardware damage and system unstable)

■ Optional

- Chassis Size 225 x 285 x 85 (mm)
- Relay Expansion Module

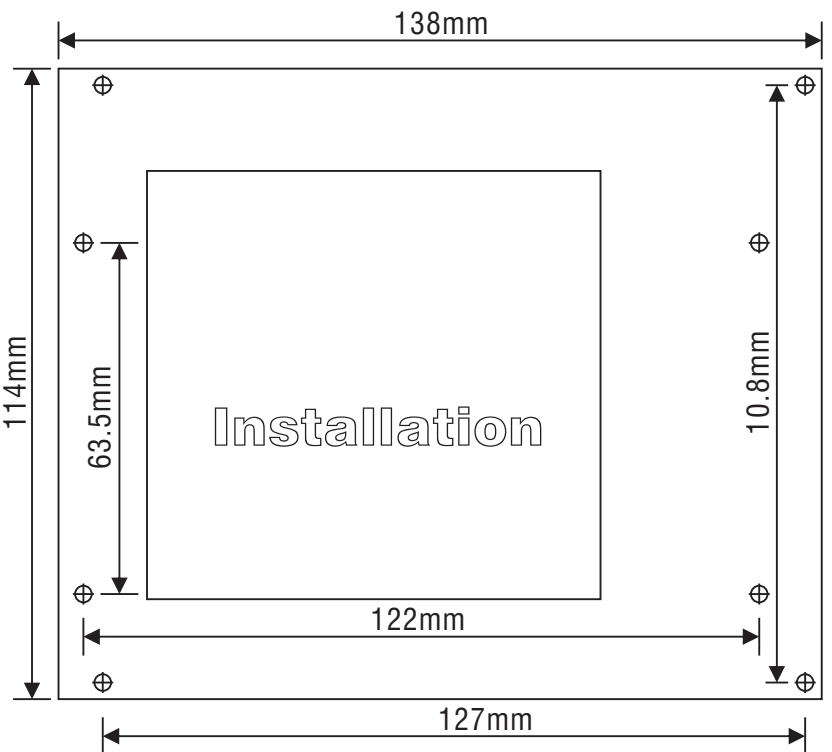

C. Structure

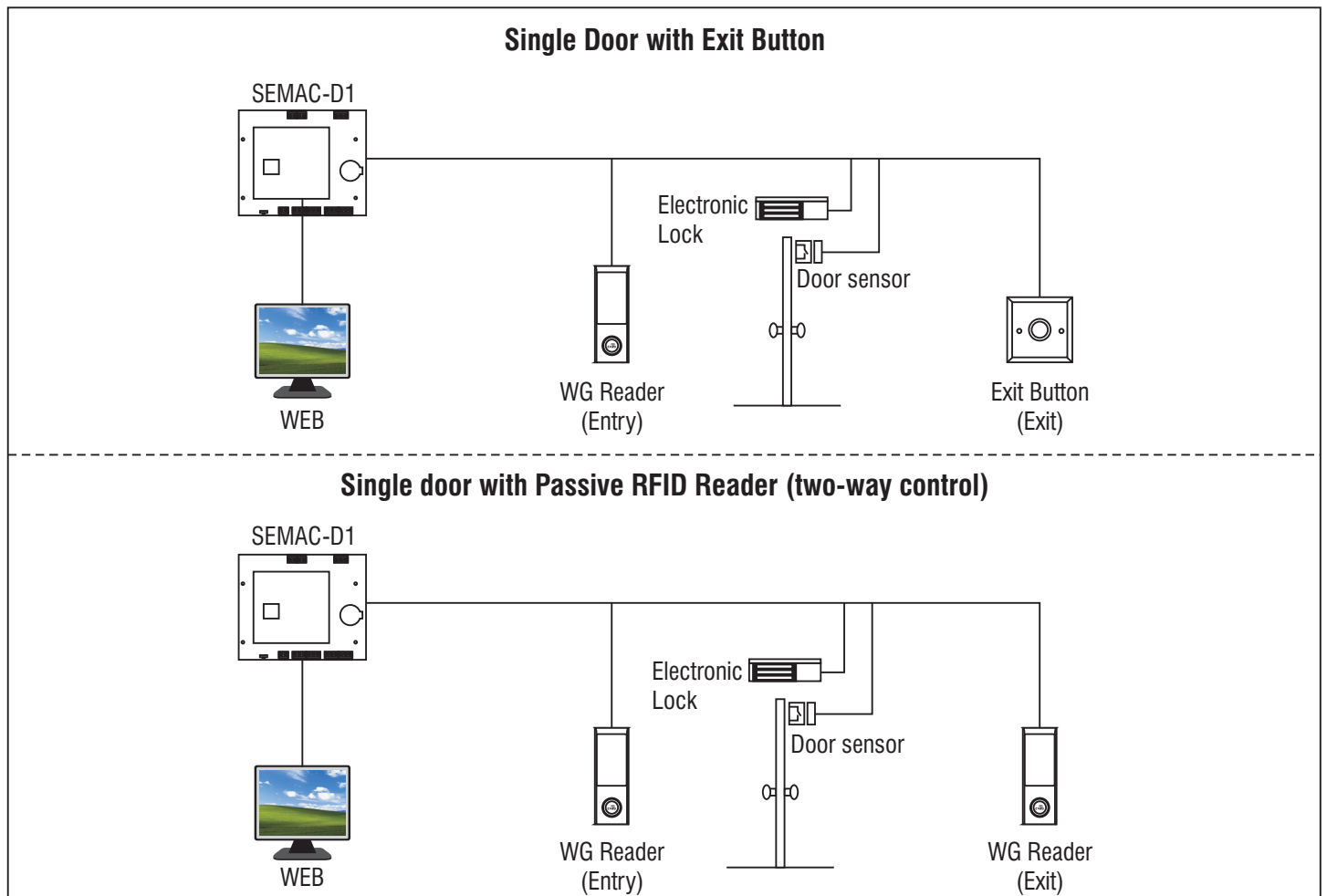

Door Relay Connection

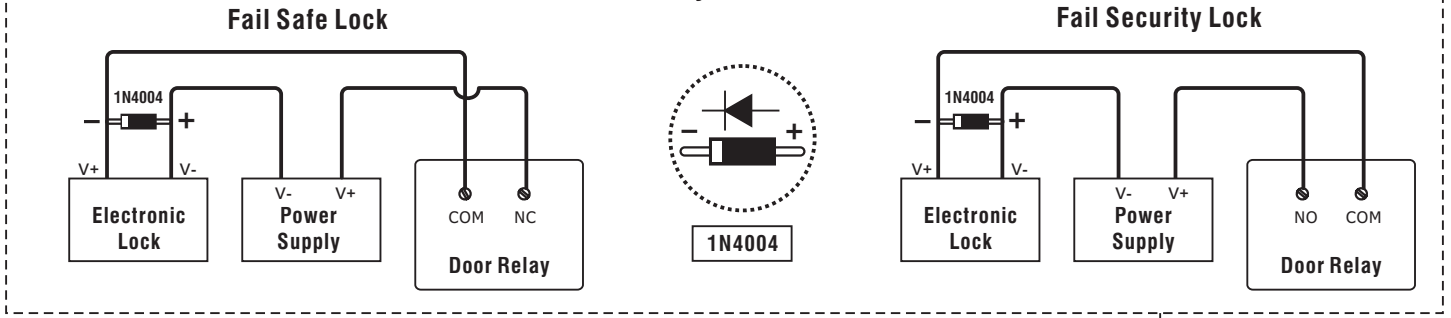

D. Wiring Diagram

